

# IM-2-25-PA0

## Electrical specifications

Winding code : PA	Symbol	Unit	Field weakening & Water cooling
Continuous torque	$T_c$	Nm	83
Continuous current	$I_c$	$A_{rms}$	10.2
Stall torque	$T_s$	Nm	70
Stall current	$I_s$	$A_{rms}$	8.2
Peak torque(for 1sec.)	$T_p$	Nm	128
Peak current(for 1sec.)	$I_p$	$A_{rms}$	25.5
Torque constant	$K_t$	$Nm/A_{rms}$	9.35
Electrical time constant	$T_e$	ms	7.2
Resistance (line to line at 25°C)	$R_{25}$	$\Omega$	5.2
Inductance (line to line)	$L_d / L_q$	mH	37.6 / 55.27
Number of poles	2p		22
Back emf constant (line to line)	$K_v$	$V_{rms}/rad/s$	5.4
Motor constant (at 25°C)	$K_m$	$Nm/\sqrt{W}$	3.35
Thermal resistance	$R_{th}$	K/W	0.129
Thermal sensor			PTC SNM100+SNM130+Pt1000
Max. DC BUS	$V_{DC}$		750
Inertia of rotor	J	$kgm^2$	0.0079
Thermal time constant	$T_{th}$	s	140
Max. continuous power dissipation	$P_c$	W	1145
Max. peak power dissipation	$P_p$	W	7159
Max. speed(at 600VDC)		rpm	3200
Based speed(at 600VDC)		rpm	564
Rated speed(at 600VDC)		rpm	3200

## T-N curve

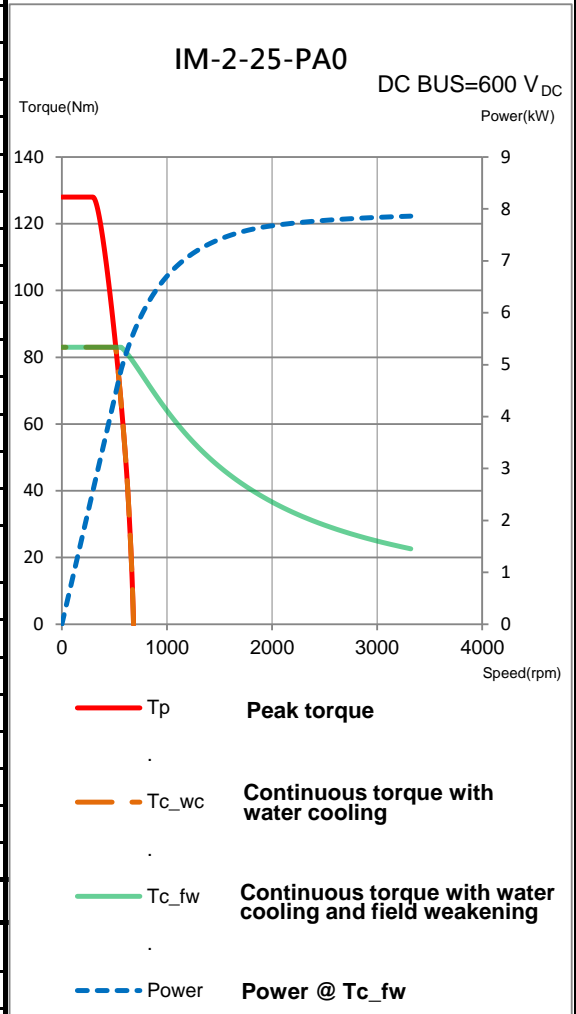

## Mechanical specifications

	Symbol	Unit	Field weakening & Water cooling
Mass of rotor	$M_r$	kg	4.09
Mass of stator	$M_s$	kg	9
Height of stator	$H_s$	mm	100
Height of rotor	$H_r$	mm	71
Length of rotor centring fit	H	mm	20
Water temperature difference for $P_c$	$\Delta\theta$	K	5
Minimum water flow	q	l/min	3.3
Max. pressure drop	$\Delta p$	bar	1

## Thermal sensor

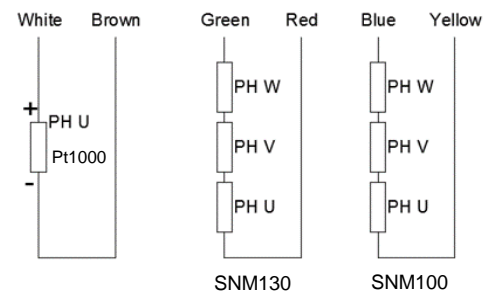
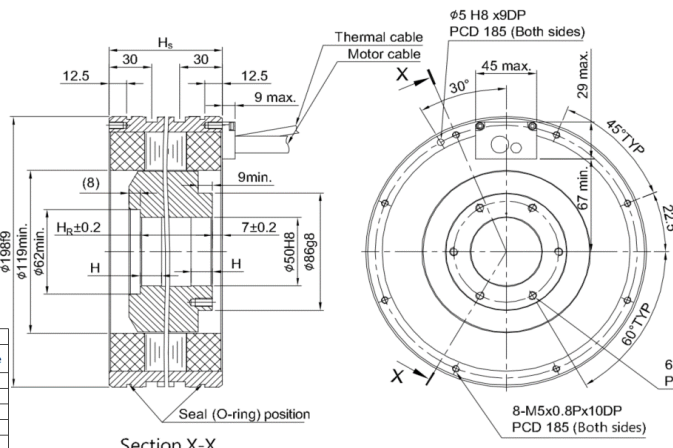

General tolerance mm	
Nominal dimension	Tolerance
~ 6	$\pm 0.1$
> 6 ~ 30	$\pm 0.2$
> 30 ~ 120	$\pm 0.3$
> 120 ~ 300	$\pm 0.4$
> 300 ~ 600	$\pm 0.5$
> 600 ~ 1200	$\pm 0.8$
> 1200 ~ 2400	$\pm 1.0$
> 2400	$\pm 1.5$

Motor wire table	
Color or wire no.	Signal
U/L1	PH U
V/L2	PH V
W/L3	PH W
Green/Yellow	GND

Except dimensions, all the specifications in the table are in  $\pm 10\%$  of tolerance

Version: 2.00

This drawing is only for reference, detail dimensions please refer to approval drawing.

Date: 2020/10/23